Homeowner's Dossier

E/One Grinder Pump System

CCC Approved Semi-Positive Displacement
Wastewater Pump for installation at:



Supplied by – Ecoflow Ltd

19B Avenger Crescent

Wigram, Christchurch 8042

03 349 2506

www.ecoflow.co.nz

iota.
services

e one
SEWER SYSTEMS

ecoflow



CCC approved E/One Wastewater Pump System

Introduction

As you will be aware, a sewer pump system is to be installed as part of the building works on all lots within the 262 on Highsted Subdivision. This sewer pump system will discharge wastewater into a pipe in the street and the onto the council sewer network.

The purpose of this document is to provide you, the owner, with information on the sewer pump system and the installation requirements. Once the system is operational, the Christchurch City Council (CCC) will own this asset and will be responsible for the ongoing maintenance of the E/One pump system.

The Pump System

The wastewater reticulation network for the subdivision has been designed to work with the E/One pump system and the Iota OneBox controller. In New Zealand, the E/One system is supplied by Ecoflow Ltd. The E/One pump system was designed in the late 1960's in the USA and over 650,000 have been installed worldwide. In New Zealand, there have been 19,000 E/One pump system installations since 2007. This system is approved by the CCC and is being used throughout the city. The pump system is a very robust and reliable piece of equipment as well as being very power efficient. The cost of power for the system averages \$25-\$35 per year and the homeowner is responsible for this cost.

Enclosed you will find information on the E/One pump system.

Telemetric Controls for Remote Monitoring

The system incorporates the Iota OneBox Telemetric Control Panel. The OneBox was designed and developed in Australia. It is used in the largest pressure sewer scheme in the world, with over 16,200 homes. The OneBox has been adopted by the CCC to monitor and regulate the flows from individual pumps within the development. This will allow the council to remotely monitor flows and to optimise the wastewater network, thus reducing maintenance inspections and repair timeframes.

Enclosed you will find information on the Iota OneBox Control Panel.

Where to obtain the Pump System

Ecoflow is the distributor of the E/One pump system and Iota OneBox Control Panel and is located in Christchurch:

Ecoflow
19B Avenger Crescent
Wigram
Christchurch
Telephone 03 349 2506 info@ecoflow.co.nz

Ecoflow is supplying the pumps, tanks and telemetry control panel for this project and has over 3800 installed pump systems in the Canterbury region. Ecoflow is the only specialised grinder pump provider with a proven 14-year track record in New Zealand. The locally based team provides full support and advice so your drainage contractor and electrician are completely supported in the installation. The council requires that the pump systems are installed by authorised drainage contractors who are on the council's approved list for pressure sewer pump systems.

Installation of the System

When your home is being built, the pump system is installed along with the rest of the drainage works. Upon completion of the installation, an Ecoflow technician will conduct an on-site inspection of the system and will notify CCC that the system is operational.

See the enclosed guide for full details of the installation requirements. Please ensure your builder, drainage contractor and electrical contractor are provided with this information.

Commissioning and Maintenance of the Pump System

Upon installation of the pump system ensure that your builder contacts Ecoflow to arrange a commission inspection and pump test. The commissioning inspection needs to occur prior to wastewater entering the tank. Ecoflow will then notify the CCC that the system is operational.

Once operational, in the event of any pump or control panel issue, the Council's maintenance contractor will inspect and maintain the system.

ecoflow

Pressure Sewer Specialists



ABOUT ECOFLOW

Ecoflow is New Zealand's largest pressurised sewer supplier. Founded in 2007 by two wastewater engineers, with their goal to become New Zealand's leading pressurised sewer system specialist.

We are proud distributors of the Environment One (E/One) system, E/One are world leaders in low pressure sewer systems having over 600,000 grinder pumps operating globally in 42 countries.

Ecoflow have installed over 10,000 E/One pressure sewer systems throughout New Zealand in both council projects as well as green-field subdivisions.

Our success is simple, we are the most knowledgeable in our field using market leading equipment. We are focused on building strong relationships with our clients offering exceptional service and support.

WHY COUNCILS AND DEVELOPERS ARE CHOOSING E/ONE PRESSURE SEWER SYSTEMS

- Better for New Zealand's environment
- Minimal impact on councils existing sewer networks
- Ideal alternative to deep gravity sewer mains
- More resilient to seismic activity – earth quakes.
- Eliminates large public sewer pump stations

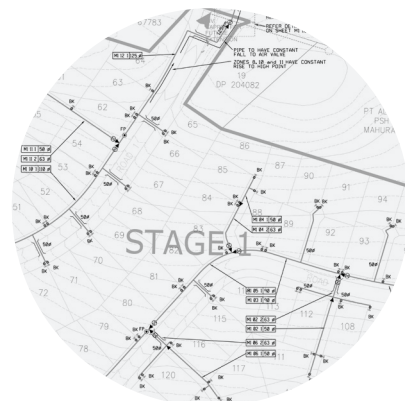

E/ONE QUALITY

For over 50 years the E/One name is synonymous with reliable, maintenance free grinder pump systems, designed with longevity in mind. Before a product is released it is subjected to meticulous performance tests. The heavy duty cast iron grinder pump is ANSI/NFS 46 Certified. It's an industrial grade pump for residential use. E/One's tank is manufactured in New Zealand and is designed and certified to AS/NZS1546 specifications. It features an integrated stainless steel ball valve with pressure relief.

SERVICE CAPABILITIES

Ecoflow is known for offering end-to-end service. We have close relationships with architects, housing companies, builders, plumbers, drain layers and electricians to achieve a superior level of customer service.

SERVICES INCLUDE:

- Network Design
- Project Management
- Supply of Quality E/One Equipment
- On-Site Delivery
- On-site Installation Training – Approved Drain layers
- Pump Installation and Commissioning
- Supply of Warranty/Consent Documentation
- On-going 24/7 Service

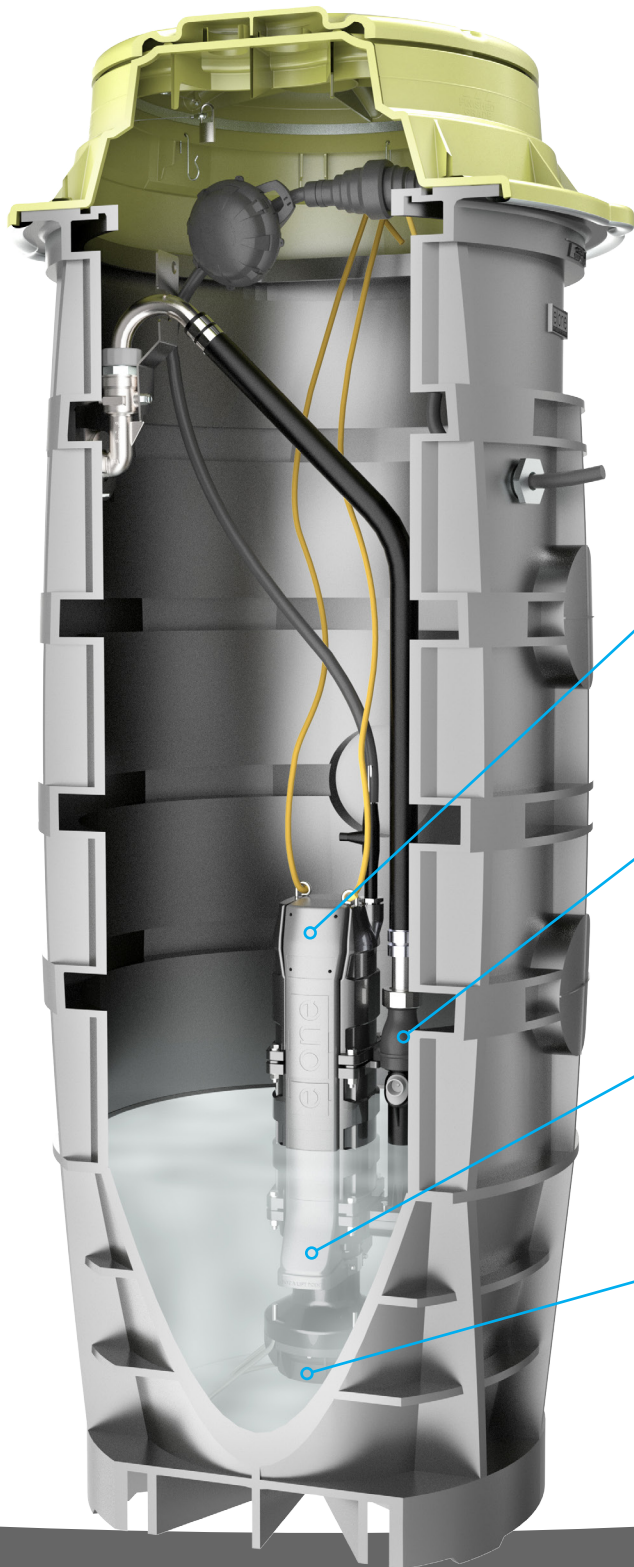

E/ONE ALARM PANEL



To maximise reliability and convenience, the E/One installation includes an IP65 weather proof alarm panel which also protects the pump from low voltage, running dry, and over pressure situations.

PRESSURE SWITCH HOUSING

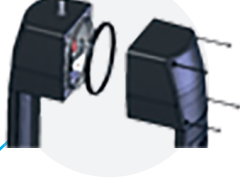

Pressure switches in the head of the pump for starting and stopping are similar to washing machine controls, eliminating the need for float switches which commonly fail due to fats, hair and rags.

INTEGRATED VALVES

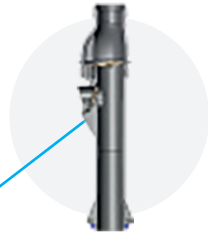

The integral non-return valve protects against system back pressure and the anti-siphon valve facilitates downhill pumping applications.

PROGRESSING CAVITY PUMP



This deceptively simple design produces a nearly constant flow under a wide range of continuously varying conditions.

GRINDER WHEEL AND SHREDDER RING



Hardened forged alloy steel cutter bars and teeth create a shearing action coupled with the high torque pump to help eliminate blockages.

- Environmentally friendly
- No preventative maintenance

- Unobtrusive, low profile installation
- Extremely low noise and odour levels

- 24 Hour emergency storage capacity
- Low power consumption \$20 to \$30 per annum

NEW ZEALAND'S LEADER IN PRESSURE SEWER

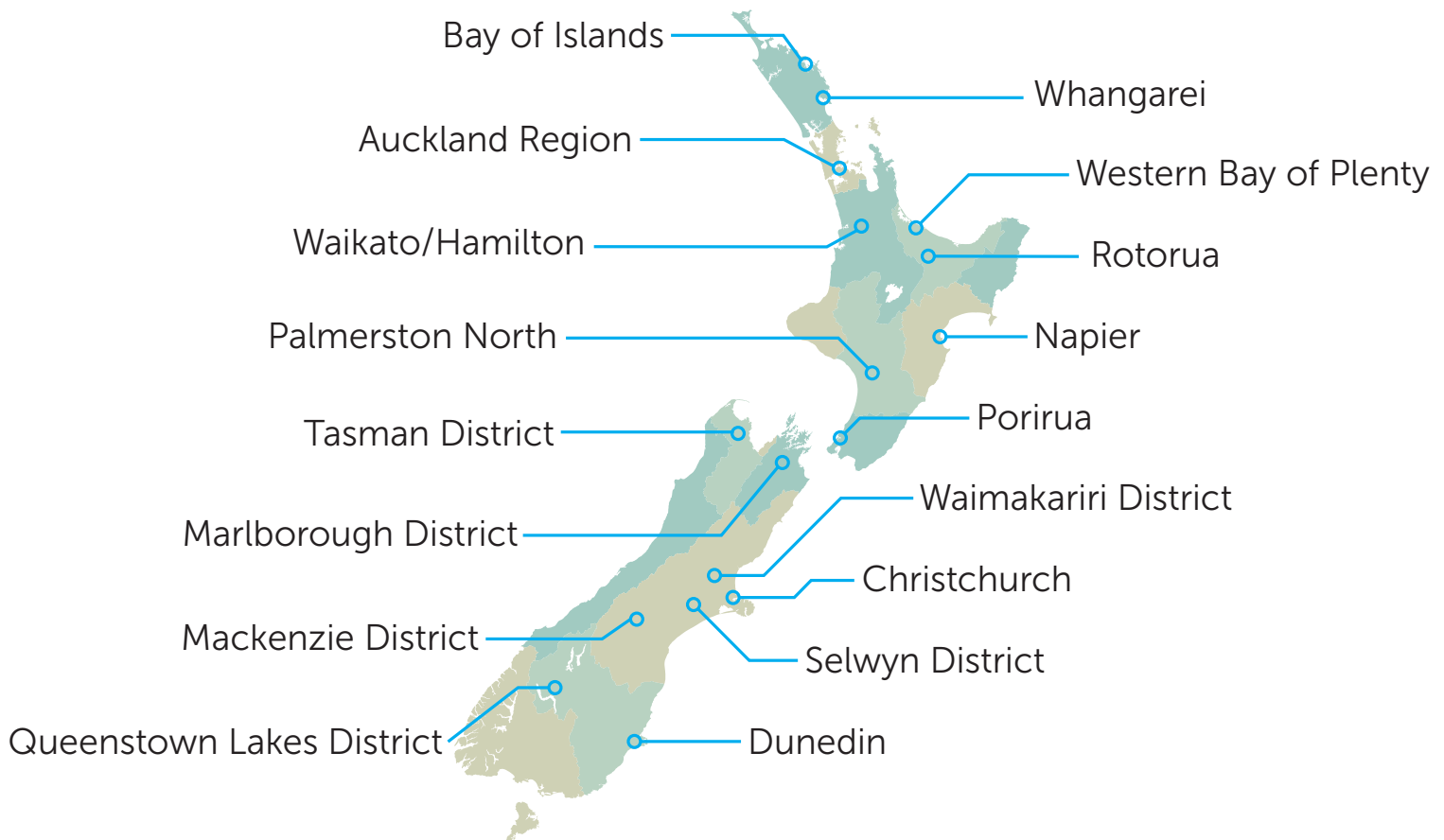



Christchurch City Council Owned/Vested

**E/One Grinder Pump Systems
with the Iota OneBox Controller**

Supplied by - Ecoflow Ltd

19B Avenger Crescent, Wigram Christchurch

03 349 2506

Notice:

**Installation of the E/One Tank System
is to be done by a CCC Authorised Drainlayer
who is approved for Pressure Sewer Tanks.**



Drainage Connection Instructions

Please avoid construction debris from entering the tank when carrying out this work.

Step 1: Choose an inlet location

Remove the lid from the tank. Choose an appropriate entry point for the 100mm PVC pipe. This must be above the tapered section of the tank (above the red line shown in the picture below). The inlet hole can be drilled in either the circular areas or in the recessed sections.



Note: Tanks to be install using Geotextile Bag

Step 2: Cut the inlet penetration

Check that the tank isn't filled with water and then using a 127mm (5") hole saw, cut a hole in the chosen location.



Step 3: Fit supplied rubber inlet grommet

Remove any burrs or shavings from the hole with a file or similar tool. Place the supplied rubber inlet grommet into the hole with the large flange to the outside of the tank. Rubber inlet grommet is cable tied to the valve inside every tank.



Additional specially designed E/One rubber inlet grommets can be supplied by Ecoflow if more than one inlet is required. **Please do not use other inlet grommets as they are thinner than the E/One grommet.**

Step 4: Prepare the PVC inlet pipe

Chamfer the 100mm PVC inlet pipe with a file or similar tool. This will make it easier to push through the rubber inlet grommet into the tank.



Draw a witness line on the pipe 80-100mm from the chamfered end. This line is where you will stop once it is visible inside the tank. Do not have more than 100mm and no less than 80mm inside the tank.

Step 5: Fit the PVC inlet pipe

Apply a film of liquid soap or pipe lubricant up to the witness line on the pipe from the chamfered end.

Push the pipe into the tank through the rubber inlet grommet. The flexible watertight seal is made once the PVC pipe has been pushed through. Pushing the pipe through will require some strength as it can be difficult.

Ensure the pipe has the required fall and check to make sure the rubber inlet grommet is seated correctly with the large flange hard up against the outside of the tank and is not pinched or rolled.

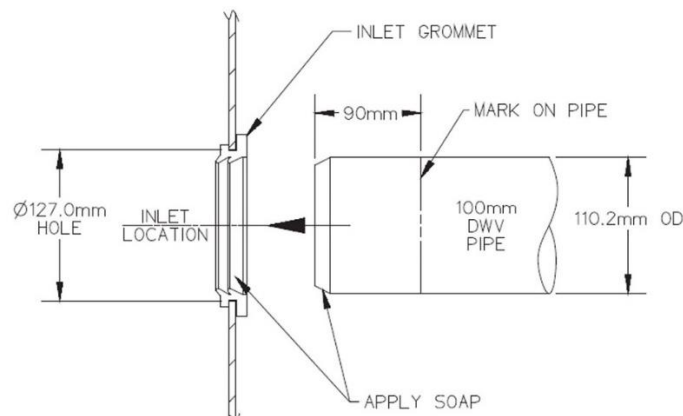
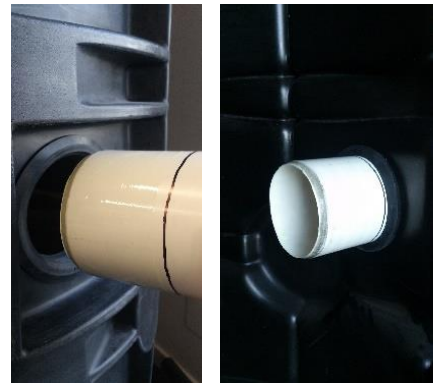

Silicone's & Epoxy

Silicone's and epoxy mortar's are not required at any stage so please do not use them.

The supplied rubber inlet grommet has been specially designed by E/One for the tank wall thickness, please do not use any other types as they won't seal correctly. The supplied rubber grommet creates a flexible watertight seal and allows for ground movement.



Step 6: Discharge Pipe Connection

Connect a 40mm OD PE100 PN16 discharge pipe to the 32mm (1 ¼ ") fitting on the chamber. Electrofitting fittings are to be used when connected to the discharge pipe onto a Council pressure sewer network.



Tank Ballast Requirement and Backfill

A concrete ballast anchor is required to prevent floatation of the tank. See the diagram below indicating the concrete ballast required. The tank can be pre-ballast if ground water is an issue. If pre-ballasting you need to use a suitable lifting method and anchor point to be used when lifting the tank in the hole. The design of this anchor point is the responsibility of the contractor. **Backfill** – Use clean compactable backfill which meets relevant local codes.

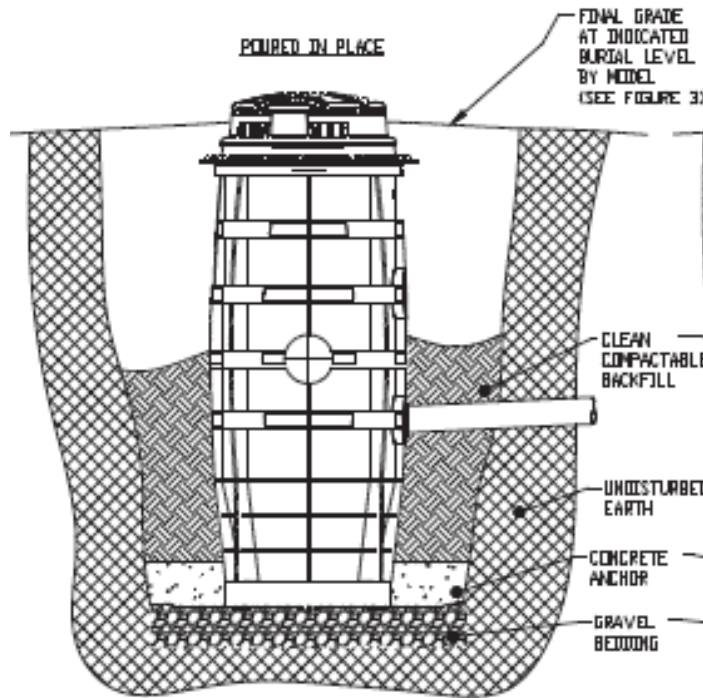

Lifting Pre-Ballasted Tank

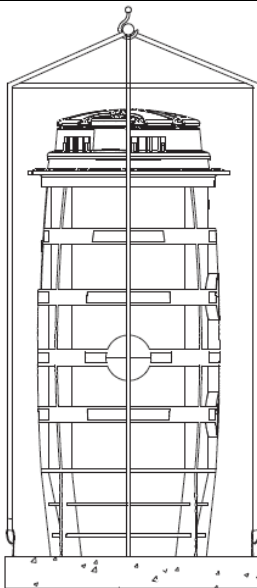

If the pre-ballast method is used, suitable lifting points must be anchored in the concrete to support subsequent handling of the tank.

The lifting points must be adequate to support the combined weight of the tank and concrete ballast, and should be sized and installed in accordance with an engineer’s recommendation and design.

Images are indicative only and are not a construction drawing.

Ecoflow and E/One take no responsibility for the lifting point anchors system design.



Electrical Cable Instructions

Step 1: Install Conduit - Install 25mm electrical conduit into to the two electrical fittings on the tank wall as shown below – using pvc glue.

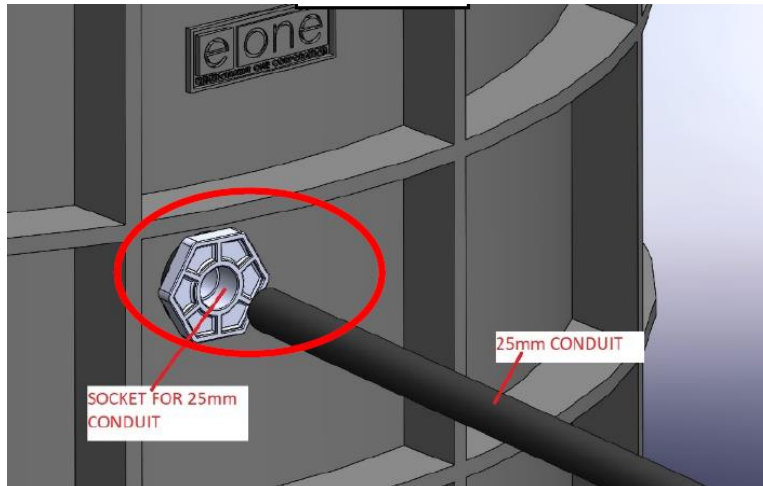

All Cables between Tanks and Control Panel are to be installed with Rigid Conduit
Do not use flexible conduit

Step 2a: Install the E-One pump supply cable

Open the lid of the tank and locate the pump supply cable connector on the inside of the tank (this is the larger single cable). Loosen the nut on the cable connector and feed the free end (end without the E/One connector) through from the inside of the tank. Pull the supply cable out through the connector until the metal crimped is level with tank opening. The free end of the supply cable is to be cut to length (if needed) and connected to the OneBox Panel. Run the cable underground in rigid conduit to the location of the Panel. Retighten the supply cable connector nut inside the tank.



E/One Pump Cable gland



Double gland for level sensor & high level float

Step 2b: Install the Level Sensor and High Level Float Cables –

As with step 2a - Locate the cable gland, this time the gland with two holes. Pull the cables for the high level alarm and level sensor through the connector to the panel – NOTE: **Leave all additional length of these cable in the tank.** Again the two cables are to be install into a 25mm rigid conduit and run to the OneBox Alarm Panel. Re-tighten the supply cable connector nut inside the tank.

OneBox Control Panel Installation Instructions

OneBox Control Panel Requirements

- Requires an **independent circuit from the main switch board.**
- A **20amp 'D' Curve** circuit breaker is to be used for a Simplex (one pump) system
- **No RCD device** to be installed.
- **240V +/- 10% to Alarm Panel (216V to 264V)**
- **A lockable isolation switch near the panel is required by CCC – supplied by Ecoflow**

Step 1: Choose an appropriate mounting location

The OneBox Panel must be mounted in an outside location and ***on the outside of the house.***

The panel must be mounted onto the outside of the house and should be within 11m of the tank. If further away, then longer cables will need to be ordered and addition costs will apply.



The panel must be mounted at an appropriate height to enable the service technician easy access in the event of a service issue.

- **Minimum of 1200mm** to the base of the panel from ground level – as per CCC SD386

All penetrations into the panel must enter the bottom of the panel enclosure

- Any extra holes made into the panel may cause moisture to enter enclosure and will void warranty.
- The panel includes a mounting bracket and screws & fitting – which are found inside the panel.
- Use sealing conduit connectors for the cable penetrations at the base of the panel.
- Install a lockable external isolation switch – Supplied by Ecoflow



Step 2: OneBox Wiring Instructions

This diagram is located on the inside of each OneBox panel door.

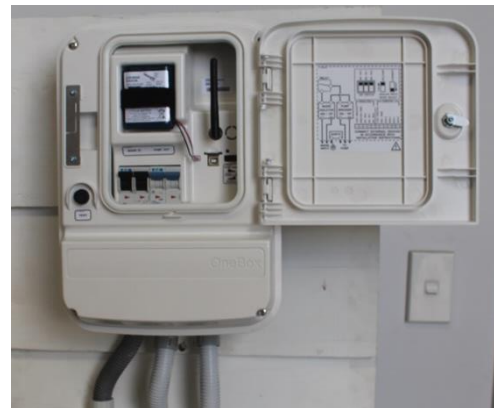
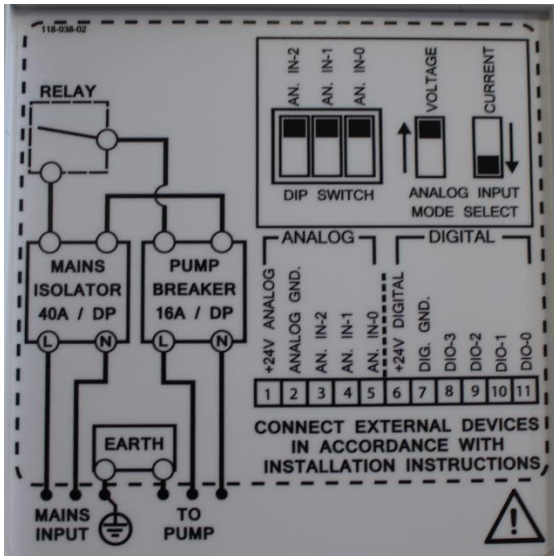

Three penetration will be made in the bottom of the panel - as shown below above

Wiring to be as shown :

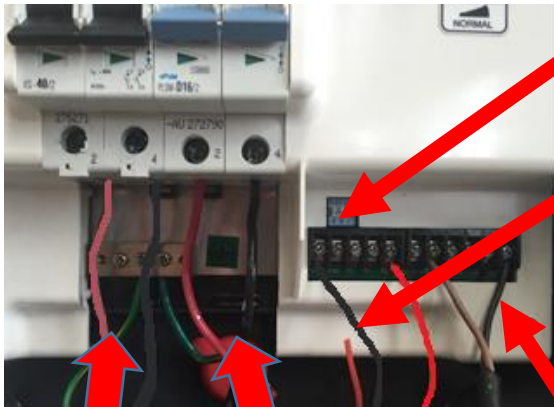

Transducer Level Sensor

Terminal 1 - +24V_A wire colour BLACK

Terminal 5 - A0 wire colour RED

RED BREATHER TUBE TO BE ALLOWED TO VENT.
DO NOT CRUSH OR PINCH BREATHER.

Remaining to be isolated.

High Level Float

7 Brown - GND

11 Black / or Blue - DO

Power Supply

Pump Cable (6 core)

**Red - Phase
Black - Neutral
Green -Earth**

-the 3 other wires can be isolated

Final Inspection of the E/One Sytem and OneBox

This inspection must be arranged prior to any wastewater entering the tank.

The system is not vested to Council unless installed by an CCC approved drainage contractor and the Ecoflow inspection is completed.

The drainage and electrical contractor will be required to supply the builder/owner a compliance form stating the installation of the systems is compliant to the requirements of both the supplier and CCC.

Ecoflow will visit each E/One station to carry out a final inspection.

The builder or home owner will need to contact Ecoflow to arrange this inspection.

Prior to inspection:

Please ensure that the following have been completed:

- The PVC drainage lateral pipe has been installed correctly
- Control Panel has been installed correctly
- Power is supplied to the Control Panel
- The tank is half full of clean water
- The tank is not full of construction debris

This allows the technician to run the pump and carry out a system test.



Upon completion of the final inspection:

Once the technician is satisfied that the E/One system has been installed as per specification, a sticker will be placed on the Control Panel door showing the phone number which is to be called in the event of an audible alarm.

**For any further technical advice please call
Ecoflow Christchurch Office 03 349 2506 or chch@ecoflow.co.nz**

Frequently Asked Questions – E/One Grinder Pumps System with the Iota OneBox Monitoring Panel

- **Q: How do I know if the grinder pump is working? How do I know if the grinder pump has stopped working?**
- A: The E/One grinder pump is controlled by the Iota OneBox monitoring panel. If your grinder pump is working properly, you shouldn't notice it at all — the pump will turn on as needed and pump down the tank; the pump will turn off after a few minutes.
- A: If your pump should stop working, the OneBox panel will send a signal to council's maintenance contractor and they will investigate and visit the site as needed.
- **Q: Am I limited to what I can put down the drain?**
- A: The grinder pump will handle all typical household waste. However, you should not allow strong chemicals, oils, baby wipes, sanitary napkins, flushable wipes, tampons, nappies, plastics, etc. to enter the pump station.
- **Q: What is the duration of operation per day?**
- A: Typically the pump will run for only 15 and 20 minutes in total per day for typical residential houses.
- **Q: What is the size of the discharge line from the grinder pumps to the street connection?**
- A: The low pressure lateral service line is typically 40mm OD polyethylene from the tank to the boundary.
- **Q: What is the average yearly electrical cost to operate a unit servicing the typical single typical home?**
- A typical family home uses around 600 – 800 litres of water per day. The E/One grinder pump flow rate is 40 L/min. Therefore the pump only operates 15 – 20 minutes per day, or 121.7 Hrs/year. The EOne pump is a 0.75kW motor (power consumption is typically between 500 – 600 watts).
Therefore $121.7\text{Hrs} \times 0.75\text{kW} = 91.3\text{kWHrs}$.
Electricity cost of $\$0.26/\text{kWhr} \times 91.3 = \mathbf{\$24/\text{year in electricity}}$.
- **Q: What do I need to know about my grinder pump?**
- A: All of the wastewater in your home from toilets, showers, dishwashers, sinks, etc. empties into the grinder pump system. When the water in the tank reaches a certain level, the pump will turn on automatically and pump out the wastewater to the sewer system. Most of the time, you won't even notice the pump running; it produces about the same level of noise as a washing machine and usually runs for only a few minutes.
- A: Take care not to dump oil, grease, paint, strong chemicals, sand, kitty litter, etc. down your drain. Feminine products and personal/cleaning wipes should be disposed of in a garbage can.

These items should not be introduced into any sewer or septic system; they can damage or cause premature problems (parts wearing out) with the pump, or build up in the tank and prevent your pump from working properly.

- **Q: What if the power goes out?**

- A: Limit your water usage as much as possible. The tank has storage capacity and should be adequate for the short term because you are not using the dishwasher, washing machine, etc.
- When the power comes on again the pump will run and it will take a few minutes to pump down the tank to a normal level.

- **Q: What do I do if alarm sounds?**

- A: The OneBox monitoring panel audible alarm will sound if the system has been in an alarm status for over 16 hours. This audible alarm will sound for a 10 minute max or until someone pushes the mute button on top of the control panel. If alarm sounds call the Council's Call Centre 03 941 8999

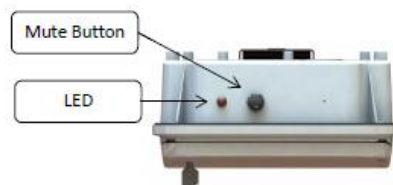

Figure 21: Top of enclosure, Mute Button and LED

Top view – push the rubber “alarm mute” button and call the Council Call Centre 03 941 8999

To avoid blockages and damage to the Pressure Sewer System the following items should **NOT** be put into the pump station:



- Glass / Metal
- Gravel, sand or aquarium stones
- Seafood or Egg shells
- Nappies, sanitary pads or tampons
- **Baby or cleaning wipes**



- Kitty Litter
- Flammable materials
- Oil / Grease
- Strong chemicals
- Petrol, diesel
- Storm-water
- Plastics

The new Pressure Sewer System



Your guide to the pressure wastewater system



Christchurch
City Council



(03) 941 8999

The pressure wastewater system

The wastewater system for this property is a pressure wastewater system.

A pressure wastewater system includes an individual pump and tank. The pump is located within the tank. The tank is located underground and you will only see the lid at the surface. Wastewater from your house flows through a pipe (a private lateral) to the tank. The tank then pumps the wastewater to the pipes in the street. From the street the wastewater goes to the wastewater treatment plant.

The pressure wastewater system is very reliable and robust. There is very little you need to do and very little that can go wrong.

The pressure wastewater system

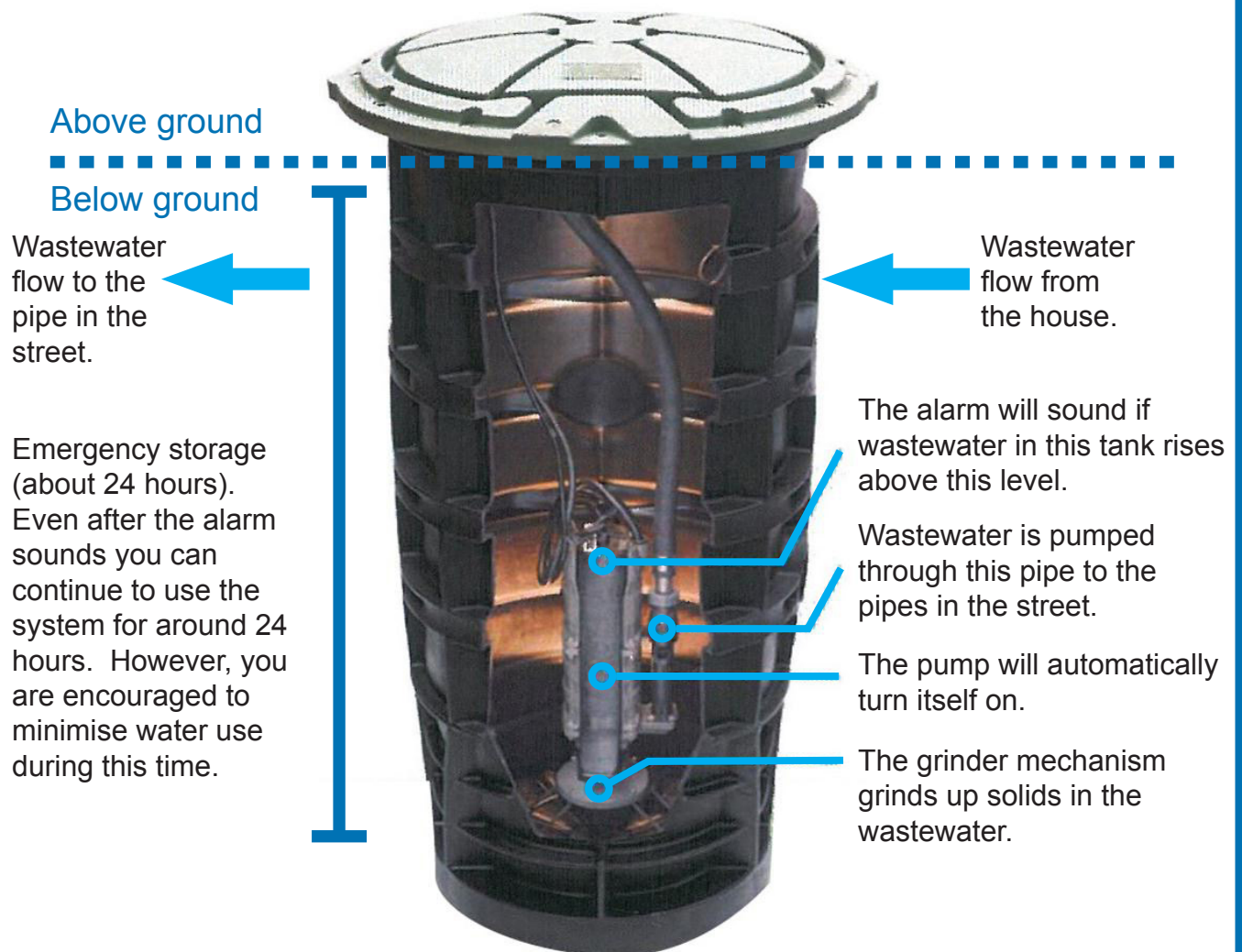

Using the system

There are a few things you need to know to ensure that the pressure wastewater system runs smoothly. The system operates like a normal wastewater system. It takes wastewater from your toilet, sink, shower, bath, dishwasher, and washing machine and transfers it to the wastewater pipes in the street, and onto the wastewater treatment plant.

To avoid blockages and damage to the pressure wastewater system there are a number of items that should not be disposed of via the system.

The following items should not be flushed down the toilet or sink:

- **wet wipes of any kind**
- **nappies, sanitary napkins, tampons**
- **gravel or sand, including stones from fish tanks**
- **seafood shells**
- **socks, rags, clothes**
- **plastic, rubber or latex products**
- **glass, metal, dental floss**
- **kitty litter**
- **explosives**
- **flammable materials**
- **lubricating oil and grease**
- **strong chemicals**
- **petrol, diesel**
- **stormwater runoff**

Before you go on holiday

Before you go on holiday, even if it is just for a few days, you should flush the pressure wastewater system before you go. This is to avoid the possibility of the system becoming smelly while you are away. **To flush the system simply run a tap in the kitchen or bathroom sink for about five minutes before you go.**

Taking care of the system

- **Do not flush any inappropriate items through the system.**
- **Do not put heavy weights on the lid of the tank. The lid can be walked on, but this should be avoided.**
- **Do not touch the valves in the boundary kit.**
- **Do not turn off the power to the pump unless evacuating in an emergency or if there is a broken wastewater pipe.**
- **Do not cover the unit in any way. This includes covering it with dirt, garden mulch, or concrete.**
- **Ensure access to the unit is available at all times.**
- **If you are going on holiday, even for just a few days, you should flush the system before you go. Simply run clean water down your kitchen or bathroom sink for five minutes (5 mins).**
- **If you do accidentally break a pipe under the ground contact the Christchurch City Council on (03) 941 8999 immediately and tell them what happened. While waiting for the pipe to be repaired minimise the amount of wastewater going through the system.**
- **Contact the Christchurch City Council on (03) 941 8999 if you install a swimming or spa pool.**
- **Contact the Christchurch City Council on (03) 941 8999 if you are making any modifications to your home which may affect the system (for example a house addition).**
- **Do not attempt to repair the system yourself. Always call the Christchurch City Council on (03) 941 8999.**